



Conifer
SYSTEMS

Environmental Solutions.
Redefined.

2023 North American Mine Ventilation Symposium



About Us

Conifer Systems designs, manufactures, installs and services state-of-the-art emissions control systems. We have delivered 500+ environmental solutions since 2004, helping companies across all industries to achieve their environmental goals.

Conifer Systems is a wholly-owned subsidiary of Archaea Energy, which was acquired by bp in December 2022. We design and manufacture environmental solutions in Houston, Texas.

500+

SOLUTIONS

30

INDUSTRIES

24/7

SERVICE



Standardized RTO Offerings for VAM Applications

- Pre-engineered 2-can and 3-can RTO solutions
- Flow rates from 2,500 to 60,000 SCFM
- Lower cost and shorter lead-time vs. custom engineered solutions

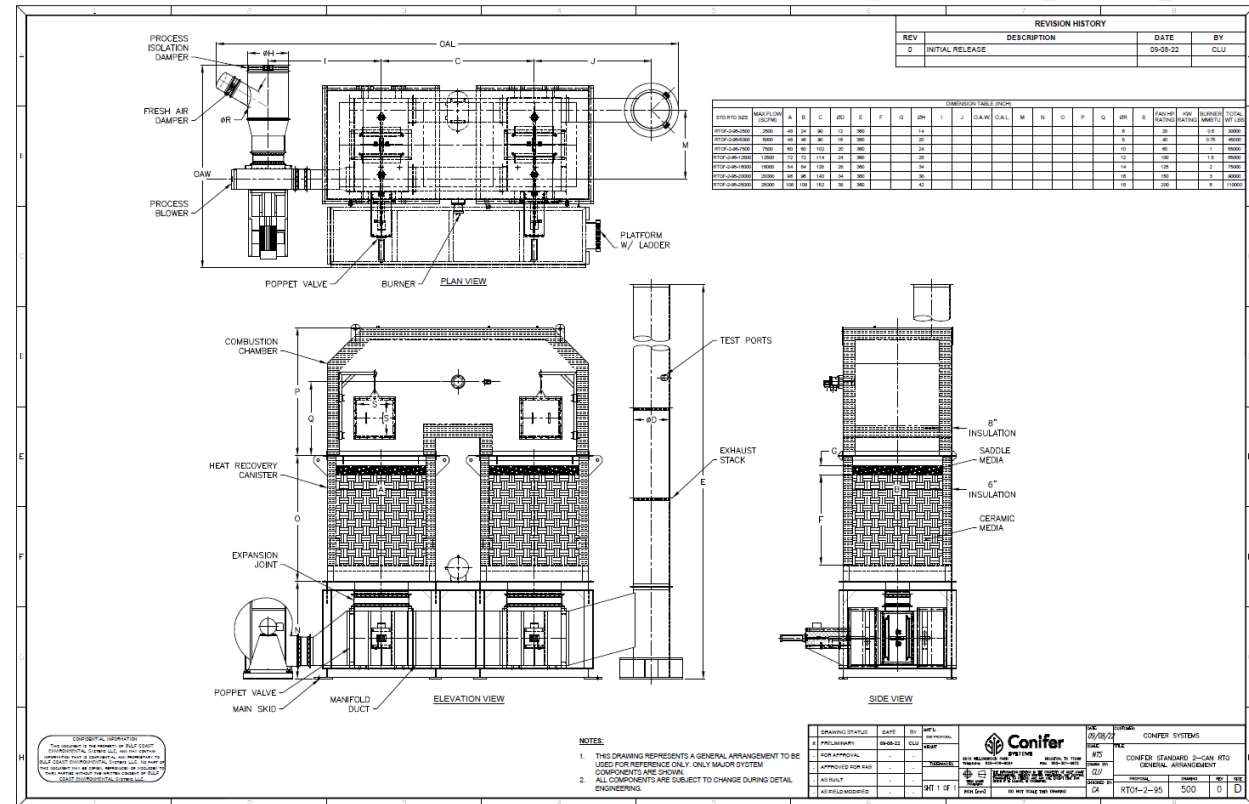
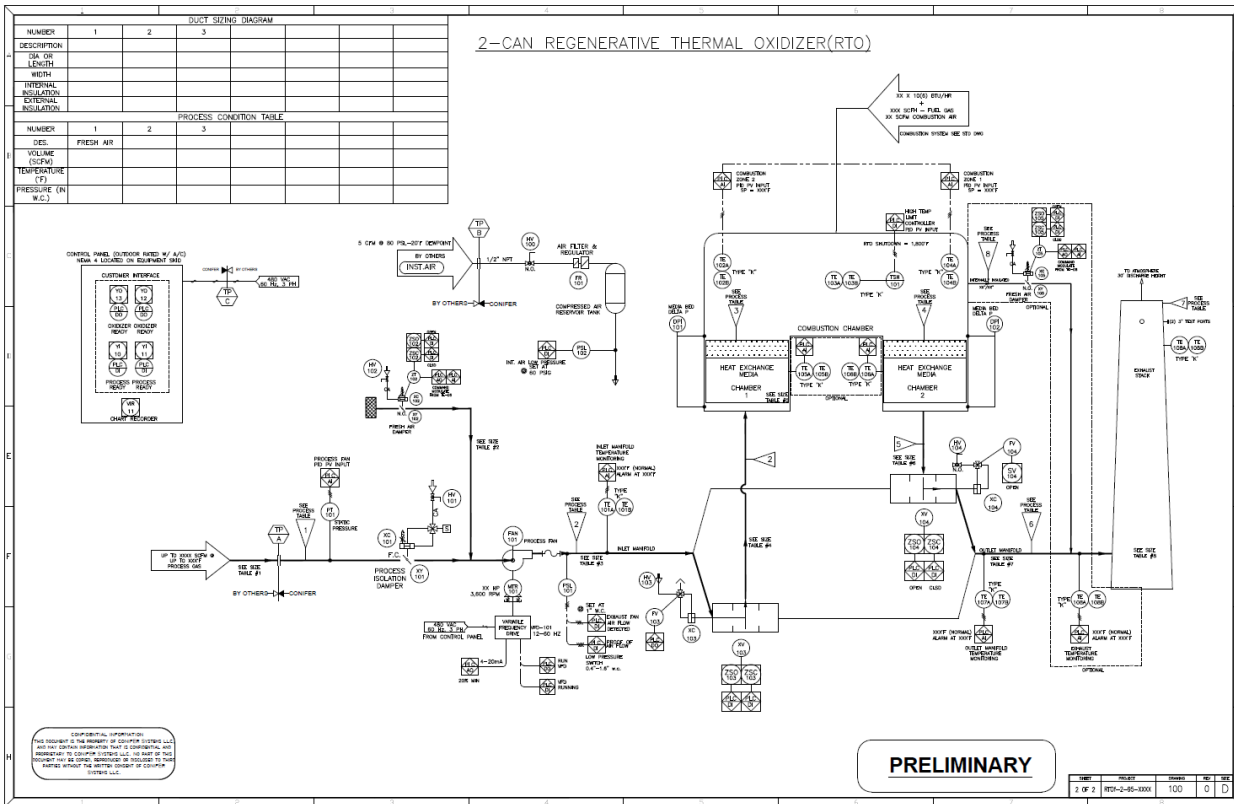

Recent VAM Project Win - Solvay Project Vulcan (Green River, Wyoming)

- Largest VAM project in the USA
- Infrastructure designed to accommodate 20% future growth
- Project awarded November 2022, fabrication commenced February 2023, commissioning scheduled to begin March 2024

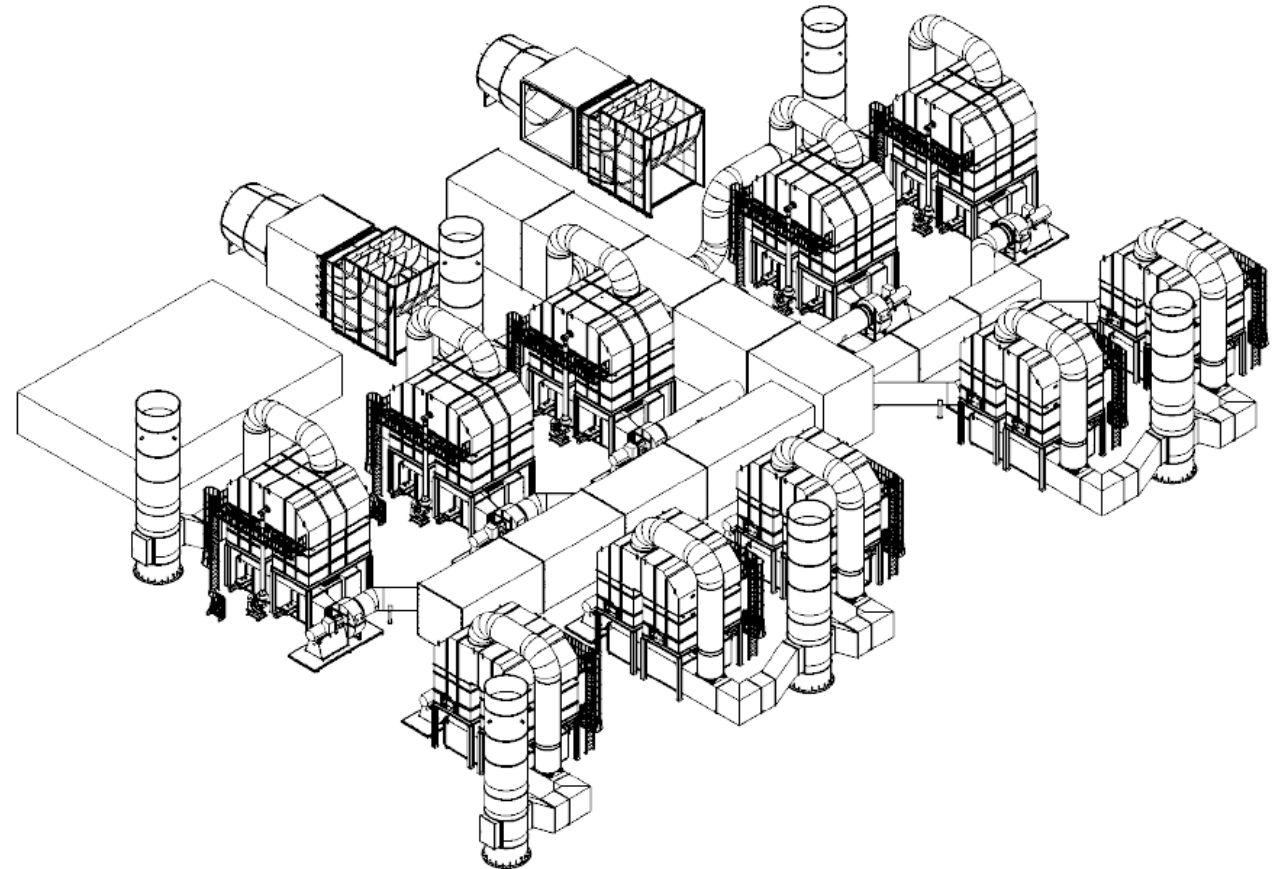

Contact Us

WEBSITE

conifersystems.com

EMAIL

sales@conifersystems.com

PHONE

+1 (832) 476-9024

